

PIER NO. 1 PHASE I BAR LIST

| EPOXY COATED REINFORCING | | | | |
|--------------------------|------|-----|------|-----------|
| MARK | SIZE | NO. | FORM | LENGTH |
| CT1 | #10 | 30 | STR. | 23'-6" |
| CV1 | #10 | 30 | STR. | 24'-2" |
| P1 | #4 | 18 | BNT. | 7'-3" |
| P2 | #4 | 15 | BNT. | 7'-9" |
| P3 | #4 | 1 | BNT. | 18'-5" |
| ① PH1 | #10 | 8 | BNT. | 26'-6" |
| ① PH2 | #5 | 12 | STR. | 28'-6" |
| ① PH3 | #10 | 8 | STR. | 25'-1" |
| PH4 | #5 | 6 | BNT. | 5'-9" |
| PV1 | #5 | 3 | BNT. | 7'-9" |
| S1 | #5 | 56 | BNT. | 19'-3" |
| PLAIN REINFORCING | | | | |
| MARK | SIZE | NO. | FORM | LENGTH |
| ② CS1 | W26 | 2 | BNT. | 750'-4" |
| ② DS1 | W20 | 2 | BNT. | 2,960'-2" |
| ② DV1 | #11 | 68 | STR. | 77'-6" |
| ③ T1 | #4 | 20 | BNT. | 14'-0" |

PIER NO. 1 PHASE II BAR LIST

| EPOXY COATED REINFORCING | | | | |
|--------------------------|------|-----|------|-----------|
| MARK | SIZE | NO. | FORM | LENGTH |
| CT1 | #10 | 15 | STR. | 23'-6" |
| CV1 | #10 | 15 | STR. | 24'-2" |
| P1 | #4 | 12 | BNT. | 7'-3" |
| P2 | #4 | 10 | BNT. | 7'-9" |
| PH4 | #5 | 6 | BNT. | 5'-9" |
| ① PH5 | #10 | 8 | BNT. | 19'-6" |
| ① PH6 | #5 | 12 | STR. | 17'-11" |
| ① PH7 | #10 | 8 | STR. | 18'-1" |
| PV1 | #5 | 3 | BNT. | 7'-9" |
| S1 | #5 | 44 | BNT. | 19'-3" |
| PLAIN REINFORCING | | | | |
| MARK | SIZE | NO. | FORM | LENGTH |
| ② CS1 | W26 | 1 | BNT. | 750'-4" |
| ② DS1 | W20 | 1 | BNT. | 2,960'-2" |
| ② DV1 | #11 | 34 | STR. | 77'-6" |
| ③ T1 | #4 | 10 | BNT. | 14'-0" |

PIER NO. 2 PHASE I BAR LIST

| EPOXY COATED REINFORCING | | | | |
|--------------------------|------|-----|------|-----------|
| MARK | SIZE | NO. | FORM | LENGTH |
| CT1 | #10 | 30 | STR. | 23'-6" |
| CV2 | #10 | 30 | STR. | 24'-6" |
| P2 | #4 | 18 | BNT. | 7'-9" |
| P4 | #4 | 36 | BNT. | 5'-0" |
| P5 | #4 | 2 | BNT. | 13'-11" |
| ① PH1 | #10 | 8 | BNT. | 26'-6" |
| ① PH2 | #5 | 15 | STR. | 28'-6" |
| ① PH3 | #10 | 8 | STR. | 25'-1" |
| PH4 | #5 | 5 | BNT. | 5'-9" |
| PH8 | #5 | 2 | BNT. | 3'-6" |
| PV1 | #5 | 2 | BNT. | 7'-9" |
| PV2 | #5 | 2 | BNT. | 6'-1" |
| S2 | #5 | 58 | BNT. | 15'-11" |
| S3 | #5 | 29 | BNT. | 14'-3" |
| PLAIN REINFORCING | | | | |
| MARK | SIZE | NO. | FORM | LENGTH |
| ② CS2 | W26 | 2 | BNT. | 815'-5" |
| ② DS2 | W20 | 2 | BNT. | 2,885'-3" |
| ② DV2 | #11 | 68 | STR. | 75'-6" |
| ③ T1 | #4 | 20 | BNT. | 14'-0" |

PIER NO. 2 PHASE II BAR LIST

| EPOXY COATED REINFORCING | | | | |
|--------------------------|------|-----|------|-----------|
| MARK | SIZE | NO. | FORM | LENGTH |
| CT1 | #10 | 15 | STR. | 23'-6" |
| CV2 | #10 | 15 | STR. | 24'-6" |
| P2 | #4 | 12 | BNT. | 7'-9" |
| P4 | #4 | 24 | BNT. | 5'-0" |
| PH4 | #5 | 5 | BNT. | 5'-9" |
| ① PH5 | #10 | 8 | BNT. | 19'-6" |
| ① PH6 | #5 | 15 | STR. | 17'-11" |
| ① PH7 | #10 | 8 | STR. | 18'-1" |
| PH8 | #5 | 2 | BNT. | 3'-6" |
| PV1 | #5 | 2 | BNT. | 7'-9" |
| PV2 | #5 | 2 | BNT. | 6'-1" |
| S2 | #5 | 46 | BNT. | 15'-11" |
| S3 | #5 | 23 | BNT. | 14'-3" |
| PLAIN REINFORCING | | | | |
| MARK | SIZE | NO. | FORM | LENGTH |
| ② CS2 | W26 | 1 | BNT. | 815'-5" |
| ② DS2 | W20 | 1 | BNT. | 2,885'-3" |
| ② DV2 | #11 | 34 | STR. | 75'-6" |
| ③ T1 | #4 | 10 | BNT. | 14'-0" |

PIER NO. 3 PHASE I BAR LIST

| EPOXY COATED REINFORCING | | | | |
|--------------------------|------|-----|------|----------|
| MARK | SIZE | NO. | FORM | LENGTH |
| CT2 | #11 | 34 | STR. | 28'-10" |
| CV3 | #11 | 34 | STR. | 27'-0" |
| P1 | #4 | 18 | BNT. | 7'-3" |
| P2 | #4 | 15 | BNT. | 7'-9" |
| P3 | #4 | 1 | BNT. | 18'-5" |
| ① PH1 | #10 | 4 | BNT. | 26'-6" |
| ① PH2 | #5 | 6 | STR. | 28'-6" |
| ① PH3 | #10 | 12 | STR. | 25'-1" |
| PH4 | #5 | 4 | BNT. | 5'-9" |
| ① PH9 | #10 | 8 | BNT. | 29'-6" |
| S2 | #5 | 58 | BNT. | 15'-11" |
| PLAIN REINFORCING | | | | |
| MARK | SIZE | NO. | FORM | LENGTH |
| ② CS3 | W26 | 2 | BNT. | 896'-10" |
| ② DS3 | W20 | 2 | BNT. | 2885'-3" |
| ② DV3 | #11 | 72 | STR. | 75'-6" |
| ③ T1 | #4 | 24 | BNT. | 14'-0" |

PIER NO. 3 PHASE II BAR LIST

| EPOXY COATED REINFORCING | | | | |
|--------------------------|------|-----|------|----------|
| MARK | SIZE | NO. | FORM | LENGTH |
| CT2 | #11 | 17 | STR. | 28'-10" |
| CV3 | #11 | 17 | BNT. | 27'-0" |
| P1 | #4 | 12 | BNT. | 7'-3" |
| P2 | #4 | 10 | BNT. | 7'-9" |
| PH4 | #5 | 4 | BNT. | 5'-9" |
| ① PH5 | #10 | 4 | BNT. | 19'-6" |
| ① PH6 | #5 | 6 | STR. | 17'-11" |
| ① PH7 | #10 | 12 | STR. | 18'-1" |
| ① PH10 | #10 | 8 | BNT. | 22'-6" |
| S2 | #5 | 46 | BNT. | 15'-11" |
| PLAIN REINFORCING | | | | |
| MARK | SIZE | NO. | FORM | LENGTH |
| ② CS3 | W26 | 1 | BNT. | 896'-10" |
| ② DS3 | W20 | 1 | BNT. | 2885'-3" |
| ② DV3 | #11 | 36 | STR. | 75'-6" |
| ③ T1 | #4 | 12 | BNT. | 14'-0" |

PIER NO. 4 PHASE I BAR LIST

| EPOXY COATED REINFORCING | | | | |
|--------------------------|------|-----|------|----------|
| MARK | SIZE | NO. | FORM | LENGTH |
| CT2 | #11 | 34 | STR. | 28'-10" |
| CV4 | #11 | 34 | STR. | 29'-6" |
| P1 | #4 | 18 | BNT. | 7'-3" |
| P2 | #4 | 15 | BNT. | 7'-9" |
| P3 | #4 | 1 | BNT. | 18'-5" |
| ① PH1 | #10 | 4 | BNT. | 26'-6" |
| ① PH2 | #5 | 6 | STR. | 28'-6" |
| ① PH3 | #10 | 12 | STR. | 25'-1" |
| PH4 | #5 | 4 | BNT. | 5'-9" |
| ① PH9 | #10 | 8 | BNT. | 29'-6" |
| S2 | #5 | 58 | BNT. | 15'-11" |
| PLAIN REINFORCING | | | | |
| MARK | SIZE | NO. | FORM | LENGTH |
| ② CS4 | W26 | 2 | BNT. | 978'-2" |
| ② DS4 | W20 | 2 | BNT. | 2847'-9" |
| ② DV4 | #11 | 72 | STR. | 74'-6" |
| ③ T1 | #4 | 24 | BNT. | 14'-0" |

PIER NO. 4 PHASE II BAR LIST

| EPOXY COATED REINFORCING | | | | |
|--------------------------|------|-----|------|----------|
| MARK | SIZE | NO. | FORM | LENGTH |
| CT2 | #11 | 17 | STR. | 28'-10" |
| CV4 | #11 | 17 | BNT. | 29'-6" |
| P1 | #4 | 12 | BNT. | 7'-3" |
| P2 | #4 | 10 | BNT. | 7'-9" |
| PH4 | #5 | 4 | BNT. | 5'-9" |
| ① PH5 | #10 | 4 | BNT. | 19'-6" |
| ① PH6 | #5 | 6 | STR. | 17'-11" |
| ① PH7 | #10 | 12 | STR. | 18'-1" |
| ① PH10 | #10 | 8 | BNT. | 22'-6" |
| S2 | #5 | 46 | BNT. | 15'-11" |
| PLAIN REINFORCING | | | | |
| MARK | SIZE | NO. | FORM | LENGTH |
| ② CS4 | W26 | 1 | BNT. | 978'-2" |
| ② DS4 | W20 | 1 | BNT. | 2847'-9" |
| ② DV4 | #11 | 36 | STR. | 74'-6" |
| ③ T1 | #4 | 12 | BNT. | 14'-0" |

PIER NO. 5 PHASE I BAR LIST

| EPOXY COATED REINFORCING | | | | |
|--------------------------|------|-----|------|----------|
| MARK | SIZE | NO. | FORM | LENGTH |
| CT2 | #11 | 34 | STR. | 28'-10" |
| CV5 | #11 | 34 | STR. | 32'-0" |
| P1 | #4 | 18 | BNT. | 7'-3" |
| P2 | #4 | 15 | BNT. | 7'-9" |
| P3 | #4 | 1 | BNT. | 18'-5" |
| ① PH1 | #10 | 4 | BNT. | 26'-6" |
| ① PH2 | #5 | 6 | STR. | 28'-6" |
| ① PH3 | #10 | 12 | STR. | 25'-1" |
| PH4 | #5 | 4 | BNT. | 5'-9" |
| ① PH9 | #10 | 8 | BNT. | 29'-6" |
| S2 | #5 | 58 | BNT. | 15'-11" |
| PLAIN REINFORCING | | | | |
| MARK | SIZE | NO. | FORM | LENGTH |
| ② CS5 | W26 | 2 | BNT. | 1059'-7" |
| ② DS5 | W20 | 2 | BNT. | 2585'-8" |
| ② DV5 | #11 | 72 | STR. | 67'-6" |
| ③ T1 | #4 | 24 | BNT. | 14'-0" |

PIER NO. 5 PHASE II BAR LIST

| EPOXY COATED REINFORCING | | | | |
|--------------------------|------|-----|------|----------|
| MARK | SIZE | NO. | FORM | LENGTH |
| CT2 | #11 | 17 | STR. | 28'-10" |
| CV5 | #11 | 17 | BNT. | 32'-0" |
| P1 | #4 | 12 | BNT. | 7'-3" |
| P2 | #4 | 10 | BNT. | 7'-9" |
| PH4 | #5 | 4 | BNT. | 5'-9" |
| ① PH5 | #10 | 4 | BNT. | 19'-6" |
| ① PH6 | #5 | 6 | STR. | 17'-11" |
| ① PH7 | #10 | 12 | STR. | 18'-1" |
| ① PH10 | #10 | 8 | BNT. | 22'-6" |
| S2 | #5 | 46 | BNT. | 15'-11" |
| PLAIN REINFORCING | | | | |
| MARK | SIZE | NO. | FORM | LENGTH |
| ② CS5 | W26 | 1 | BNT. | 1059'-7" |
| ② DS5 | W20 | 1 | BNT. | 2585'-8" |
| ② DV5 | #11 | 36 | STR. | 67'-6" |
| ③ T1 | #4 | 12 | BNT. | 14'-0" |

PIER NO. 6 PHASE I BAR LIST

| EPOXY COATED REINFORCING | | | | |
|--------------------------|------|-----|------|----------|
| MARK | SIZE | NO. | FORM | LENGTH |
| CT2 | #11 | 34 | STR. | 26'-11" |
| CV6 | #11 | 34 | STR. | 34'-6" |
| P1 | #4 | 18 | BNT. | 7'-3" |
| P2 | #4 | 15 | BNT. | 7'-9" |
| P3 | #4 | 1 | BNT. | 18'-5" |
| ① PH1 | #10 | 4 | BNT. | 26'-6" |
| ① PH2 | #5 | 6 | STR. | 28'-6" |
| ① PH3 | #10 | 12 | STR. | 25'-1" |
| PH4 | #5 | 4 | BNT. | 5'-9" |
| ① PH9 | #10 | 8 | BNT. | 29'-6" |
| S2 | #5 | 58 | BNT. | 15'-11" |
| PLAIN REINFORCING | | | | |
| MARK | SIZE | NO. | FORM | LENGTH |
| ② CS6 | W26 | 2 | BNT. | 1141'-0" |
| ② DS6 | W20 | 2 | BNT. | 863'-0" |
| ② DV6 | #11 | 72 | STR. | 21'-6" |
| ③ T1 | #4 | 24 | BNT. | 14'-0" |

PIER NO. 6 PHASE II BAR LIST

| EPOXY COATED REINFORCING | | | | |
|--------------------------|------|-----|------|----------|
| MARK | SIZE | NO. | FORM | LENGTH |
| CT2 | #11 | 17 | STR. | 26'-11" |
| CV6 | #11 | 17 | BNT. | 34'-6" |
| P1 | #4 | 12 | BNT. | 7'-3" |
| P2 | #4 | 10 | BNT. | 7'-9" |
| PH4 | #5 | 4 | BNT. | 5'-9" |
| ① PH5 | #10 | 4 | BNT. | 19'-6" |
| ① PH6 | #5 | 6 | STR. | 17'-11" |
| ① PH7 | #10 | 12 | STR. | 18'-1" |
| ① PH10 | #10 | 8 | BNT. | 22'-6" |
| S2 | #5 | 46 | BNT. | 15'-11" |
| PLAIN REINFORCING | | | | |
| MARK | SIZE | NO. | FORM | LENGTH |
| ② CS6 | W26 | 1 | BNT. | 1141'-0" |
| ② DS6 | W20 | 1 | BNT. | 863'-0" |
| ② DV6 | #11 | 36 | STR. | 21'-6" |
| ③ T1 | #4 | 12 | BNT. | 14'-0" |

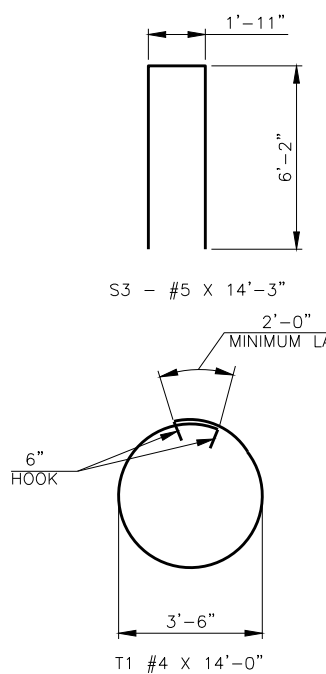
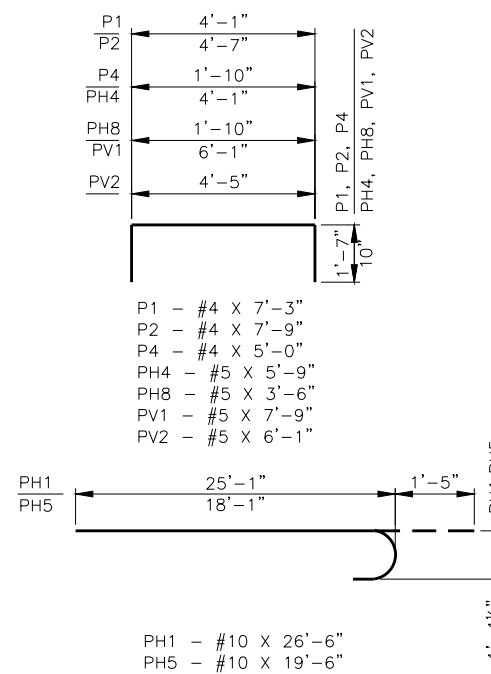
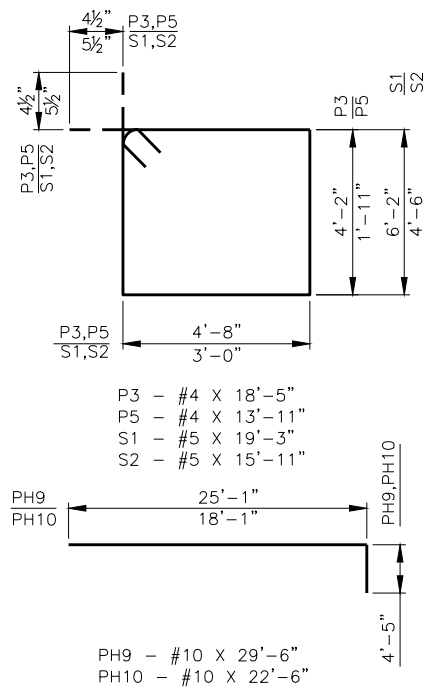

- ① BAR LENGTH DOES NOT ACCOUNT FOR MECHANICAL COUPLER. CONTRACTOR SHALL ADJUST LENGTH AS NECESSARY.
- ② LENGTH SHOWN DOES NOT ACCOUNT FOR SPLICES. CONTRACTOR MAY ADD SPLICES AS NECESSARY, BUT PAYMENTS WILL NOT BE MADE FOR EXTRA LENGTH REQUIRED FOR SPLICES.
- ③ INCLUDED IN THE CONTRACT PRICE FOR DRILLED SHAFT.
- ④ USE 9'-8" SPLICE LENGTH FOR #11 REINFORCING BARS.

| | | | |
|---------|--------|---------------------------|--------------|
| DESIGN | M.R.S. | SH-48 OVER CIMARRON RIVER | CREEK COUNTY |
| DRAWN | E.B.R. | | |
| CHECKED | M.R.S. | | |
| APPROV. | B.J.K. | | |
| SQUAD | CEC | JOB PIECE NO. 27925(04) | SHEET NO. 45 |

PIER BAR LIST